

# quDIS

Displacement Sensor

Manual V2.2.9



## Index

1.	Introduction.....	3
2.	Safety and maintenance.....	3
2.1	Legend .....	3
2.2	General instructions .....	4
2.3	Environmental conditions .....	4
2.4	Electrical installation .....	5
2.5	Preventive maintenance .....	5
2.6	Safety testing.....	6
2.7	Cleaning.....	6
3.	Measuring principle.....	7
4.	Technical information.....	9
5.	Sensor heads .....	11
5.1	Connection .....	12
5.1.1	Align collimated single sensor axis.....	12
5.1.2	Align three-axis cinematic mount for angle measurements .....	14
6.	Hardware description.....	15
6.1	Rear side.....	15
6.2	Front side.....	15
6.3	D-Sub 9-pin .....	16
6.4	SMA Clock connection.....	16
6.5	First setup.....	17
7.	Software installation .....	18
8.	Firmware configuration.....	19
8.1	Firmware update .....	19
8.2	Hardware ID.....	20
8.3	Upgrade option .....	20
9.	Daisy software .....	21
9.1	quDIS GUI .....	21
9.2	Position tab.....	23
9.3	Alignment tab.....	24
9.3.1	Working range .....	25
9.4	Interfaces tab.....	26
9.4.1	Ethernet.....	26
9.4.2	A-quad-B and HSSL interfaces .....	27
9.4.3	Angle measurement .....	33
9.5	Single- and dual-pass.....	33
9.6	Ambient Measurement Unit (AMU).....	33
9.7	External Synchronization.....	35

10. Measurements ..... 40  
 10.1 Relative measurement ..... 41  
 10.2 Angle measurement ..... 41  
 11. Quick-start-guide ..... 42  
 12. FAQ / Troubleshooting ..... 43  
 13. Known Bugs ..... 43

## 1. Introduction

The quDIS is a unique, high-precision measuring device that works on the principle of interferometry. By using frequency spectroscopy and its sophisticated algorithm, stable and highly precise measurements in the sub-nanometer range are possible.

With the quDIS it is possible to measure up to three external cavities covering a broad variety of applications, e.g., displacement measurements, vibrometry, angle measurements and drift measurements.

## 2. Safety and maintenance

### 2.1 Legend



**Caution**

General risk of danger.



**Warning**

Risk of injury or death.



**Warning**

Risk of electric shock. High voltages present.

## 2.2 General instructions



The equipment, as described herein, is designed for use by personnel properly trained in the use and handling of mains powered electrical equipment. Only personnel trained in the servicing and maintenance of this equipment should remove its covers or attempt any repairs or adjustments. If malfunctions are suspected, immediately return the part to the vendor for repair or replacement. There are no user-serviceable parts inside the electronics. Modified or opened electronics cannot be covered by the warranty anymore. Take special care in case of connecting products from other manufacturers. Follow the “General accident prevention rules”.



If this equipment is used in a manner not specified by the manufacturer, the protection provided by the equipment may be impaired. Do not operate the instrument outside the specified supply voltages or environmental range. In particular, excessive moisture may impair safety.



For laboratory use only. This unit is intended for operation from a normal, single-phase supply, in the temperature range from 5°C to 40 °C, with relative humidity (RH) between 20 % and 80 %.

## 2.3 Environmental conditions

Warning. Operation outside the following environmental limits may adversely affect operator safety:



- Indoor use only
- Maximum altitude: 2000 m
- Temperature range: 5 °C to 40 °C
- Maximum humidity less than 80 % RH (non-condensing) at 31 °C
- To ensure reliable operation the unit should not be exposed to corrosive agents or excessive moisture, heat, and dust. If the unit has been stored at a low temperature or in a high-humidity environment, it must be allowed to reach ambient conditions before being powered up.

## 2.4 Electrical installation



The unit must be connected only to an earthed fused supply of 100 to 240 V (USA, Japan, and EU).

Use only power supply cables provided by the manufacturer, other cables may not be rated to the same current. The unit is shipped with appropriate power cables for use in Europe. When shipped to other territories the appropriate power plug must be fitted by the user.



**Never connect any cabling to the electronics when contacts are exposed!**

Avoid short-cuts.



**Prevent electrical shock from electronic.** To prevent electrical shock do not remove the cover of the control unit. Unplug the power cord and all other electrical connections and consult qualified service personnel when servicing or cleaning. Operate only under dry conditions and at room temperature.

## 2.5 Preventive maintenance



The equipment contains no user serviceable parts. There is a risk of severe electrical shock if the equipment is operated with the covers removed. Only personnel authorized by the vendor and trained in the maintenance of this equipment should remove its covers or attempt any repairs or adjustments. Maintenance is limited to safety testing and cleaning as described in the following sections.

## 2.6 Safety testing



Safety testing in accordance with local regulations, should be performed on a regular basis, (typically once per year for an instrument in daily use).

Caution. The instrument contains a power supply filter. Insulation testing of the power supply connector should be performed using a DC voltage.

## 2.7 Cleaning



Disconnect the power supply before cleaning the unit. Never attempt to clean the quDIS by immersion into any liquid. Never allow water to get inside the case. The quDIS parts are sensitive to any kind of liquid. Do not use any type of abrasive pad, scouring powder, or solvent, e.g. alcohol or benzene. Please note that all parts of quDIS are cleaned in our production facility.

If a ferrule of an optical fiber is contaminated, clean it with a dry optical cloth designed for fiber optic connection adapters.

Use an optic bulb blower to remove dust from optics.

### 3. Measuring principle

The measuring principle of the quDIS is based on laser interferometry. Stable lasers with low bandwidth and superposition of its coherent radiation allowing the observation of interference phenomena. The detected signals indicate optical path length changes with sub-nanometer resolution.

#### Interferometry - sub-nanometer accuracy

All kinds of interferometers make use of the same principle. A laser beam with high coherence length is split up in two different paths, one reference arm and one measurement arm. When the two beams are superimposed again, constructive, and destructive interference  $I(x)$  can be observed in dependency on the modification of the optical length of the measurement arm. But changes in the interference pattern can also be caused by an alternation of the target reflectivity or adjustment drifts due to movement. This method does also not indicate the direction of a target movement and has the uncertainty of the periodicity the interference pattern.

The setup is inspired by a Fabry–Pérot interferometer. Fiber coupled laser light leads to a sensor head where 4% of the light is reflected to the detector, too. The rest passes the cavity, is reflected, and guided to the detector. The graph is showing the intensity at the detector while the mirror is constantly moved into one direction.

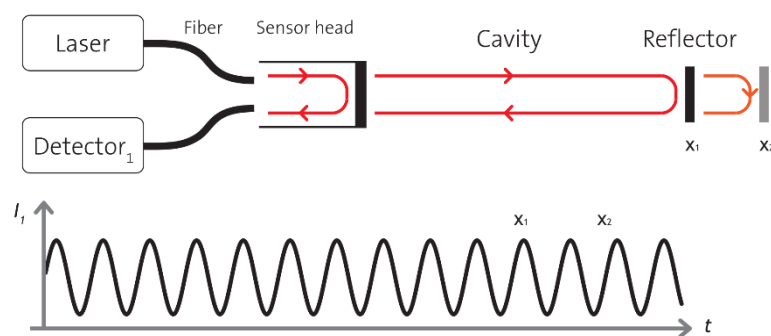
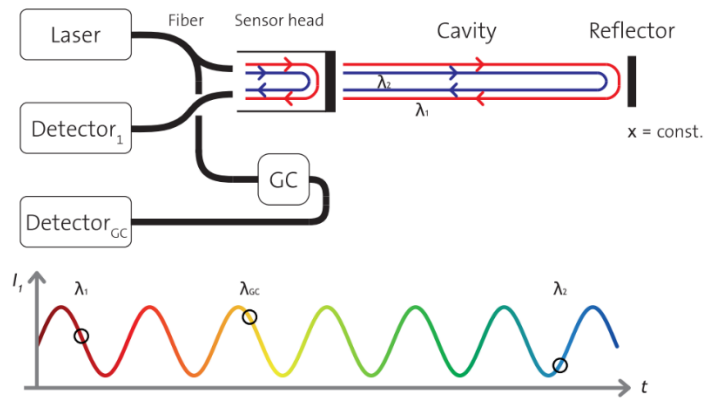

Figure 1: Basic setup example and interference signal with movement

#### Interference spectroscopy – Frequency stabilization and analysis

Beside the optical path length changes, modification of the laser wavelength at a constant path also leads to signal modulations by interference  $I(\lambda, x_{const})$ . The wavelength is swept by electric laser control, introducing an artificial motion over multiple wavelengths that avoids the relative blindness in static situations. We call this feature "interference spectroscopy".

Tuning the wavelength also causes a similar interference pattern as moving the mirror. The graph shows the intensity on a detector with linear decreasing wavelength over time. The absorption lines of an acetylene cell are used for precise wavelength control.



By changing the laser wavelength in a fast up and down sweep  $\Delta\lambda/\Delta t \gg \Delta x/\Delta t$ , relative length changes of the optical path can be determined simply by counting the interference fringes in the pattern and determining the phase at a fixed wavelength. An internal optical reference cavity stabilizes the wavelength change into a linear wavelength sweep. This measurement method is not affected by the contrast nor the intensity of the detected signal. Other methods only monitor the intensity (arcsin) or its deviation (arctan) at a constant wavelength leading to typical periodical error patterns.

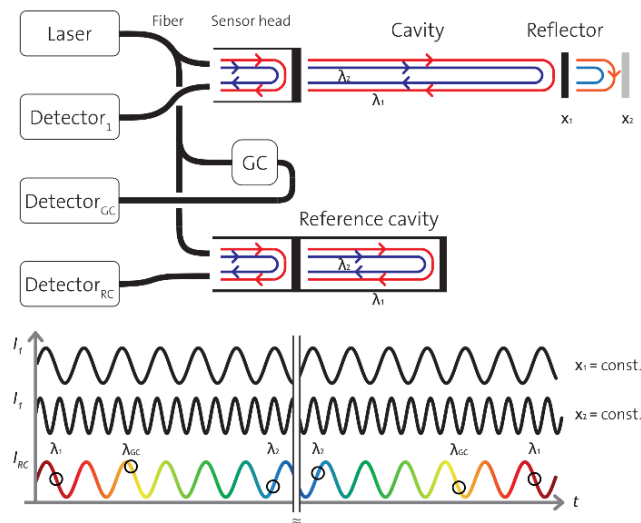

The fiber-based set-up is completed by an internal reference cavity. The graph shows the signal of the internal reference  $I_{RC}$  with adjusted wavelength change in colour and the two cavities  $x_1$  and  $x_2$  in black. Analysing the interference pattern, a lot of information is revealed about the measured cavity.

## 4. Technical information

### Sensor

Sensor axes	3
Type of interferometer	Fiber interferometer
Fiber input connectors	FC Narrow-Key-Slot Mating Sleeves
Type of sensor	Confocal displacement sensor

### Interferometer

Laser source	DFB laser (class 1)
Laser power	< 400 $\mu$ W
Wavelength (IR)	1535 nm
Laser linewidth	< 5 MHz

### Interfaces <sup>\*1</sup>

PC interface	USB 3.0, ethernet
Digital out protocol	AquadB & HSSL
Digital out Connector	HDMI
Signal levels AquadB / HSSL	LVTTTL / LVDS

### Operations

Operating systems	Windows, Linux
Supplied software	GUI, DLL, LabVIEW, Python, Command line
Alignment support	Numerical, graphical

### Accessories

Sensor heads	Vacuum, low temperature
Fibers and feedthroughs	Single mode, vacuum, low temperature
Ambient measurement unit	
Position output adapter	LVDS to RS-422 (RS-485) A-quad-B

### Hardware

Dimensions	440 x 350 x 50 mm
Weight	4 kg
Power consumption	< 30 W, at 90 to 264 VAC

### AMU - Ambient measurement unit<sup>\*3</sup>

Dimensions	38 x Ø58 mm
Connector	RJ45
Cable length	4 m
Weight	75 g
Sampling rate	10 Hz
Temperature	± 0.1°C (-5 ... 50°C)
Pressure	±1 hPa (300 ... 1100 hPa, 0 ... 65°C)
Relative humidity	± 2 % (10... 90% RH, 5... 55°C)
AMU accuracy	±1 ppm

\*1: optional available

## 5. Sensor heads

To measure with the quDIS, sensor heads with the appropriate optics are used. Depending on the desired measurement and target, there are different sensor heads to choose:

- If the target is a retroreflector, a collimated beam is recommended. These sensor heads are available with different housing and beam diameters.
- In the case of a mirror or a surface, the beam is focused on the target. As a result, for example, measurements can be made at a very short distance, the angle tolerance can be very high, or a very small spot size can be achieved.
- There are also individual sensor heads, e.g. a three-axes kinematic mount for angle measurement.

Customized sensor heads are also available. Use in ultra-high vacuum (UHV) and low temperatures is also possible.

## 5.1 Connection

The fiber connection on the quDIS is an FC / APC fiber connector. Make sure that the APC socket is plugged into the connections of the quDIS (The green colored fiber end goes in to the quDIS). The sensor heads usually have an FC / PC or FC / SMA connection.

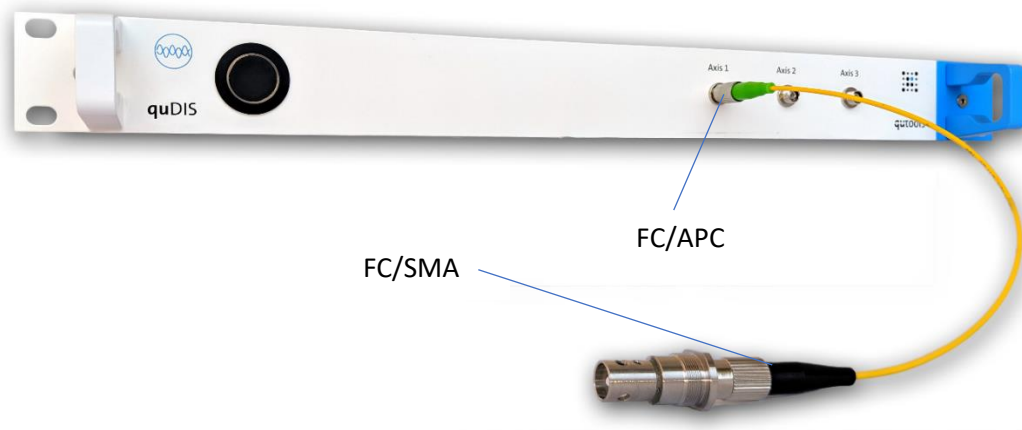

### 5.1.1 Align collimated single sensor axis

Before running the measurements, the sensor head must be aligned in the x-y axis and, if necessary, focused. To align with the target, it is advisable to use the alignment laser or to connect a fiber checker to the fiber coming from the sensor head. The sensor head can then be aligned so that the reflected beam is coupled in again. This can be checked with a piece of paper that is rise against the optics (**Do not touch the optics with the paper - contamination possible**).

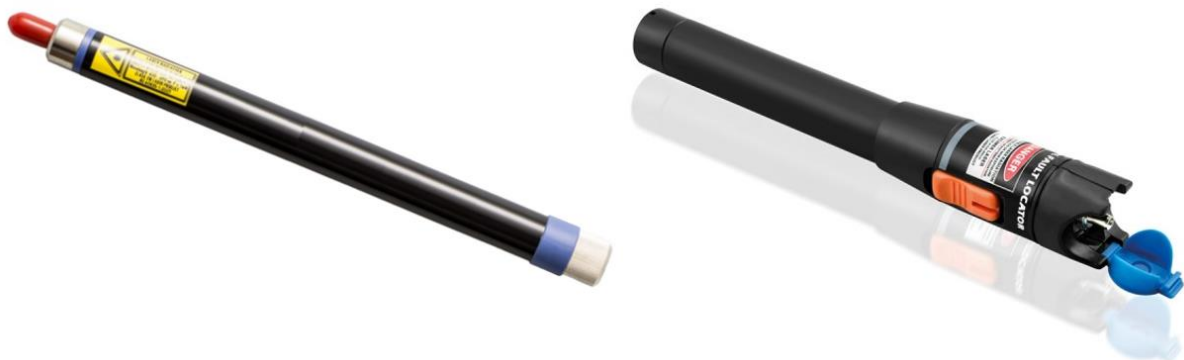

Figure 2: Examples of different fiber checkers

After the coarse alignment, the fine alignment via the optics mount is next. The reflected laser beams must hit the glass lenses of the collimator optics. The fastest way is using a piece of paper see the position of the reflecting laser beam and adjust the mount with a hex key vertically and horizontally.

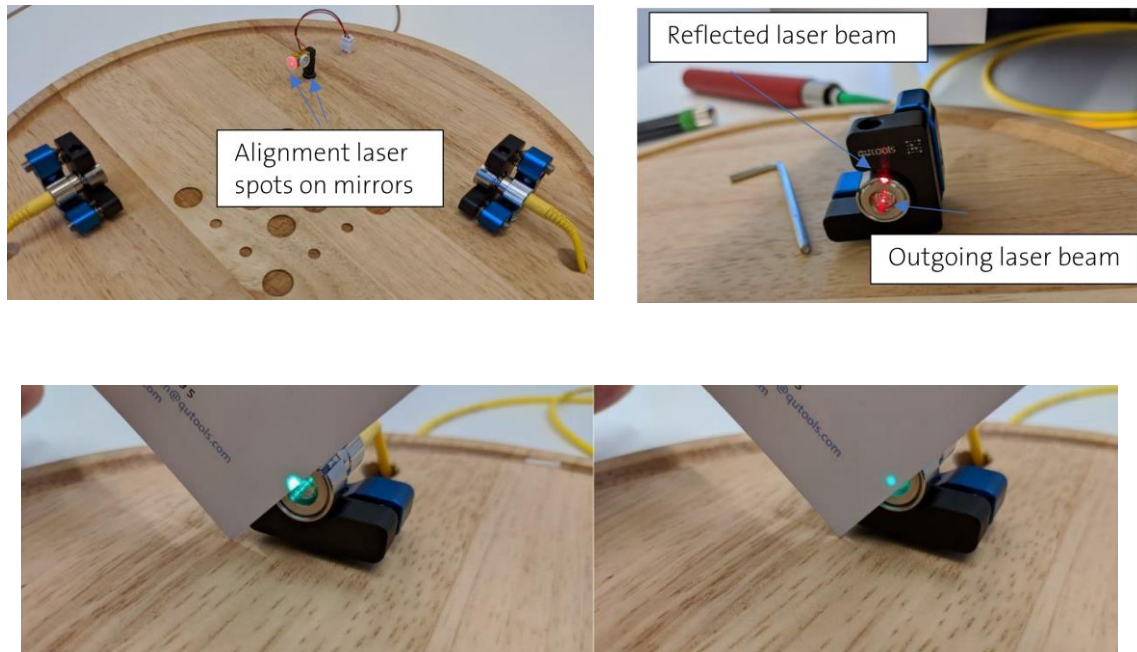
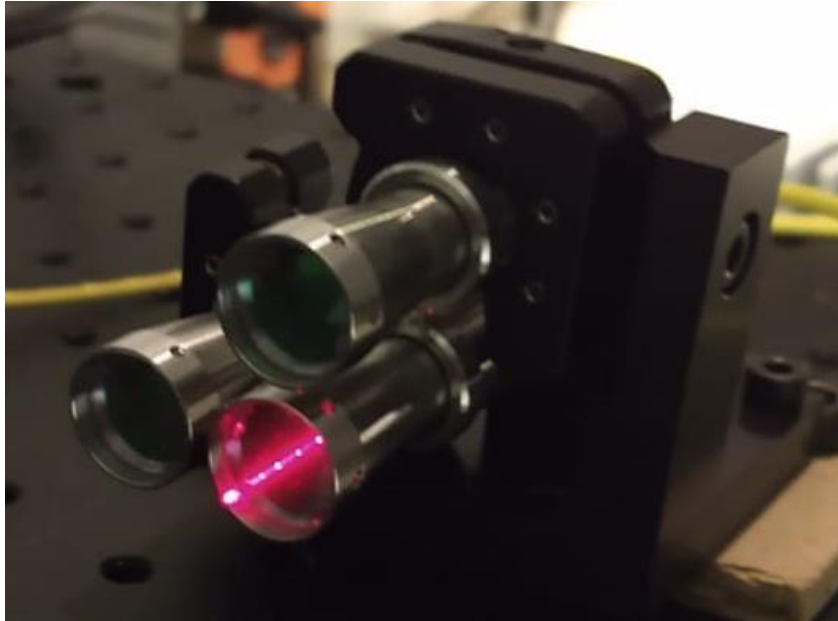

Figure 3: The left top image shows the back reflex of the beam. The right one shows blocking the outgoing beam and shining through the paper – in that case, the back reflex is hidden and blocked by the paper. When the adjustment is done at both laser beams and the outgoing and reflected beam overlap roughly, the two fibers can be connected to the quDIS.

The fine adjustment is made with a view to the maximum intensity with the quDIS (9.3 Alignment tab). The alignment tab in the software shows the signal on the photodiode of different axis. Select one of the axes and tune its optical mount with the hex key until the fringes in the alignment view grow, doing that for each angle of each axis – four times. The higher the amplitude of the fringes, the more stable the signal.

### 5.1.2 Align three-axis cinematic mount for angle measurements

Furthermore, as with the three-axis cinematic mount for angle measurement, the sensor head and two kinematically mounted optics may have to be set.



## 6. Hardware description

### 6.1 Rear side

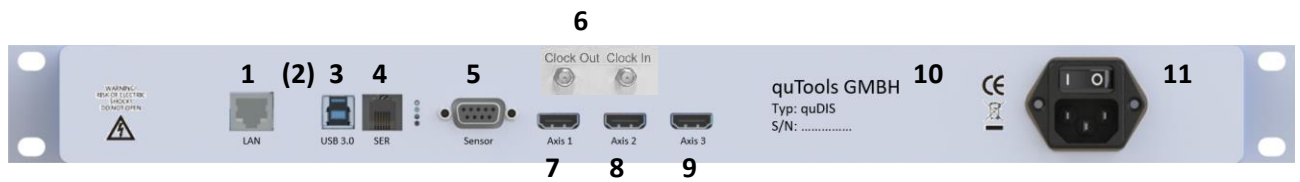

Figure 4: Rear side of the quDIS

#	Physical port	Description
1:	LAN port	connection with PC Software version $\geq$ 2.1.0, optional
(2):	USB 2.0	In quDIS Version SN < SN J 02 0026 still available, which can be used with previous software versions < 1.2.5
3:	USB 3.0	connection with PC Software version $\geq$ 14.10.2020
4:	Serial	Reserved
5:	D-Sub, 9-pin	Sensor/Ambient Measurement Unit (AMU) and Synchronisation Trigger, see <a href="#">6.3 D-Sub 9-pin</a>
6	SMA	Clock in & Clock out, newer devices only
7-9:	HDMI	HSSL and A-quad-B, see <a href="#">9.4.2 A-quad-B and HSSL interfaces</a>
10:	Serial number	
11:	Rubber connector	Power supply

### 6.2 Front side



Figure 5: Front side of the quDIS

- 1: On/Off – Button
- 2-4: Optical fiber connection  
Type FC-APC

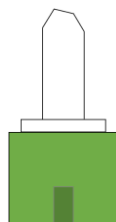

Figure 6: APC fiber connector with angled finish and green cable

It is important to use the right APC fiber connector.

Otherwise, the connector may be damaged and there will be no signal.

Furthermore, the cleanliness of the fibers must be ensured!

protection

### 6.3 D-Sub 9-pin

The D-Sub connector is used as a general purpose input/ output (GPIO) and has the following pin assignment:

Table 1 - D-Sub pin assignment with standardized numbers

Pin number	Description
1	AMU power supply
2	AMU data
3	AMU connect
4	AMU reserved
5	Sync trigger input. It uses LVTTTL signal levels with 5V tolerance. The rising edge is used for synchronization and as start-trigger. The input pin must be a minimum of 50 ns in state low before and a minimum of 50 ns in state high after the rising edge.
6	AMU ground
7	AMU clock
8	AMU LED
9	Sync trigger output using LVTTTL signal levels. The rising edge of the signal is used.

### 6.4 SMA Clock connection

Please connect and disconnect the SMA-connectors with both devices switched off.

Table 2 - Clock Input and Output specifications

Clock Input Frequency	2...100MHz (+/- 1000ppm)
Clock Out Frequency	10 MHz
Signal level	-6 ... +6 V
Signal form	sinusoidal, square wave
Min. Input level	+/-50mV
Duty cycle	50,00 %
Impedance	50 Ohms

Connector	SMA
-----------	-----

## 6.5 First setup

- Supply power to the quDIS via the AC power input and turn it on using the power switch.
- Connect the quDIS to a PC using the USB 3.0 connector.

## 7. Software installation

The quDIS software can be installed on Windows 7, 8, 8.1, and 10 for both 32- and 64-bit versions. The current version can be downloaded at: <https://qutools.com/qudis/> or given by your contact.

On Windows, using the zip archive quDIS-V... .zip	Extract the zip archive to a directory of your choice. Install the device driver in the “usbdriver” directory using dpinst32.exe or dpinst64.exe, whatever conforms to your Windows version.
--	---

The following software will now reside in the extracted directory:

Data or folder	Description
daisy(.exe)	“Data Analysis and Imaging System” – the main control software for the quDIS. (See chapter 9 <a href="#">Daisy software</a> )
nhflash(.exe)	The firmware update tool.
firmware	The firmware files.
userlib	The directory contains the custom programming library, with HTML documentation and LabView wrapper Vis.
usbdriver	USB driver package for Windows 32 and 64 Bit.

## 8. Firmware configuration

### 8.1 Firmware update



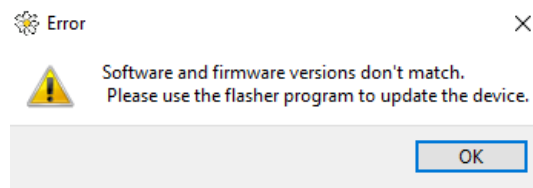

Attention: Naturally, firmware updates are a delicate process and can potentially harm the device if done incorrectly. Please read and follow the instructions carefully.

Flashing a quDIS may be necessary if an update has taken place and new firmware must be installed. If the Daisy version does not match the installed firmware, the following message is displayed in the Daisy:

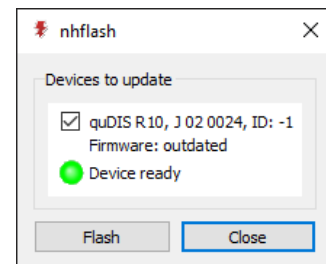

Before the firmware update can be installed, it must be ensured that the quDIS is connected via USB and that no other software (Daisy.exe) is running in the background. nhflash is started for flashing. nhflash shows the detected devices, whether the device is ready and the status of the current firmware:



The quDIS is flashed with "Flash". When  Update complete appears the flashing, process is successful. **After flashing the turn the quDIS off and on.**

## 8.2 Hardware ID

The Hardware ID is a (positive) number stored in the device so that it can be used to distinguish between multiple quDIS that are connected to the same PC. If the Daisy software detects more than one device, it asks the user to select a device using the Hardware IDs and serial numbers. Also, the DLL uses the ID to identify a device. If device discrimination is an issue, individual IDs should be programmed.

To assign a device ID start Daisy.exe, locate "id.ngc" in the installation folder with the file manager and drag it into the program window (or open the program menu using ctrl + F9 and select file/ load panel). Enter an individual ID and press "Save". Close the program window and restart the device.

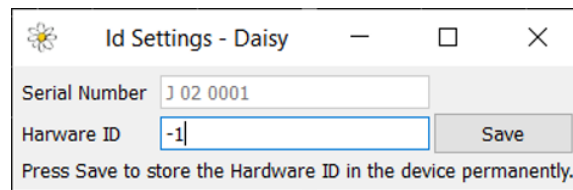

Figure 7: Programming the Hardware ID

## 8.3 Upgrade option

Some features of quDIS are optional. Software options may be bought together with the devices or upgraded/downgraded on-site by entering a device specific key. The serial number of the quDIS is required when ordering an upgrade key.

To inspect the active options or to install a new one start Daisy. In the file manager, locate "feature.ngc" in the installation folder and drag it into the program window (or open the program menu using ctrl + F9 and select file/load panel). Enter the key obtained from the vendor and press Enter. Close the program window and restart the device.

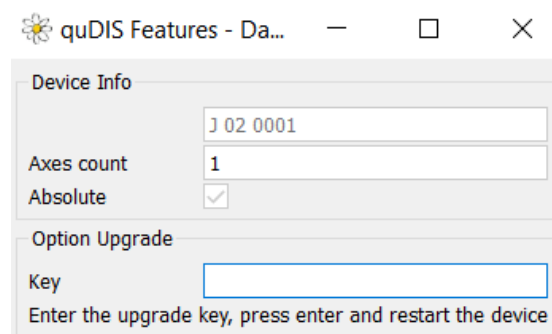

Figure 8: Option upgrade

## 9. Daisy software

The Daisy GUI is started by daisy.exe. It provides several functions which allow the full control of the device. The GUI is extendable by drag and drop \*.ngc-files into the main window or on the daisy.exe in the file manager itself. The \*.ngc-files can be found in the daisy main folder.

All tabs and all graphs can be decoupled from the main window by double-clicking them. Settings of Data Views and Edit Boxes can be changed manually via right clicking on them.

Note that some features depend on installed options. If they are not available for your device, they are typically invisible in the software.

### 9.1 quDIS GUI

The user interface consists of several tabs for different tasks.

If the Daisy.exe is executed, the Daisy window opens. A connected quDIS is recognized.

#### Windows and tab:

By default, three tabs are displayed in the Daisy window. The following global information and setting options are displayed in the window:

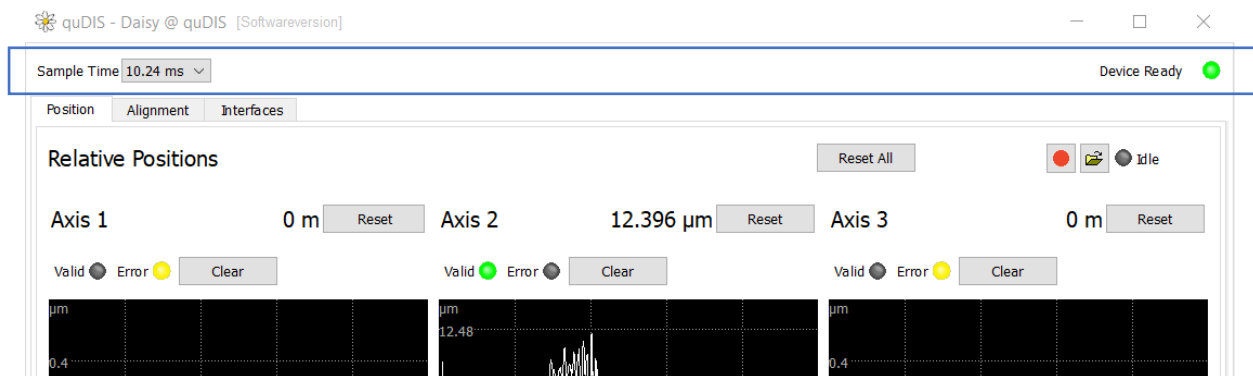



Figure 9 - Daisy qudis top panel

**Sample time:** Setting the sample time from 40μs to 2.621 s

**Status indicator:** Indicates the status of the quDIS:

- Device Ready : Device is ready for measurement
- Device Preparing : Device is in the alignment process.



## 9.2 Position tab

It shows the relative positions:

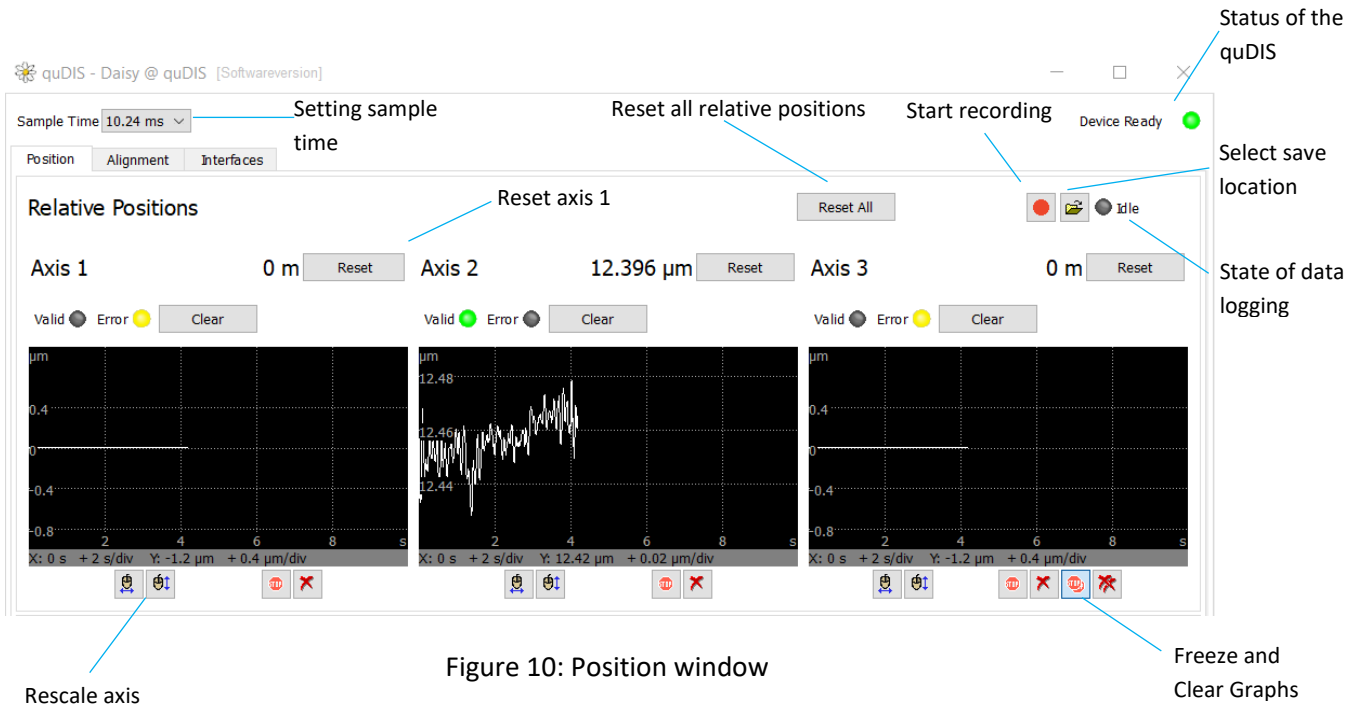
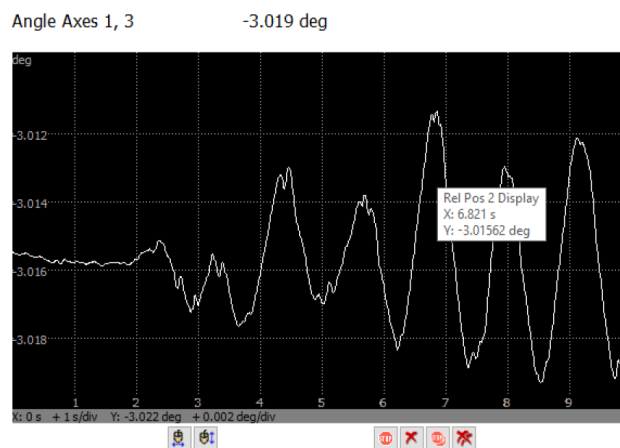

Figure 10: Position window

If the mouse cursor is moved over some elements like the error LED a tooltip is displayed.

If the mouse cursor is moved onto a certain point of the graph, the corresponding signal values are displayed:



### 9.3 Alignment tab

The “Alignment view” shows the intensity pattern of the measured cavities. To obtain the position-measurement-results enough feedback from the cavity is needed. If the setup is right, fringes will be visible. For optimal results, a signal amplitude of at least 4000 and fringes approach near zero, as there is destructive interference here, is suggested. It is also possible to change the Preamp Gain of the photodetectors for each axis here to adjust the quDIS to very high or low reflectivity. There is also the tab for setting the working range.

Be aware, that changes in Alignment settings may result in a corrupted displacement measurement. Not every change in Alignment will be notified in the axis status.

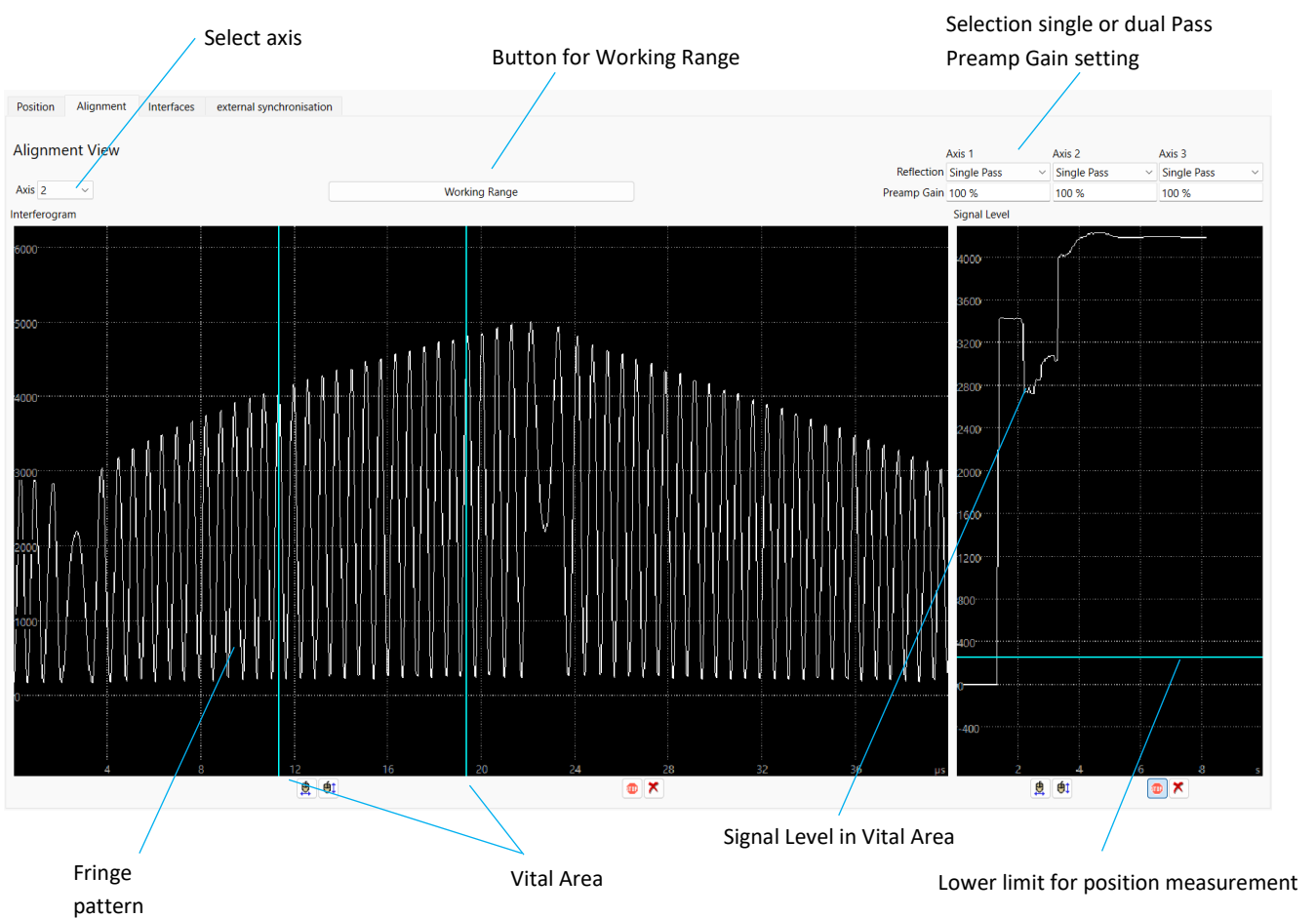

### 9.3.1 Working range

The desired measuring range and the speed of the target can be selected with the “Working Range” window. By sliding the blue triangle to the left and right side, you can set the min. and max. distance of your cavity. The orange speed limit can be set for displaying certain working range limits. As seen, more speed is accompanied with a smaller working area. As the orange speed limit changes no device settings, it is possible to have fast movement in the middle of the working area, while moving slowly at the extrema. A linear stage for example will need some acceleration time anyway. Depending on the speed setting, the working range also changes. After pressing “Apply”, the quDIS automatically adjusts to these parameters. This setting process can be seen in the progress bar below. If the quDIS has reached the required operating point, the quDIS is ready to measure.

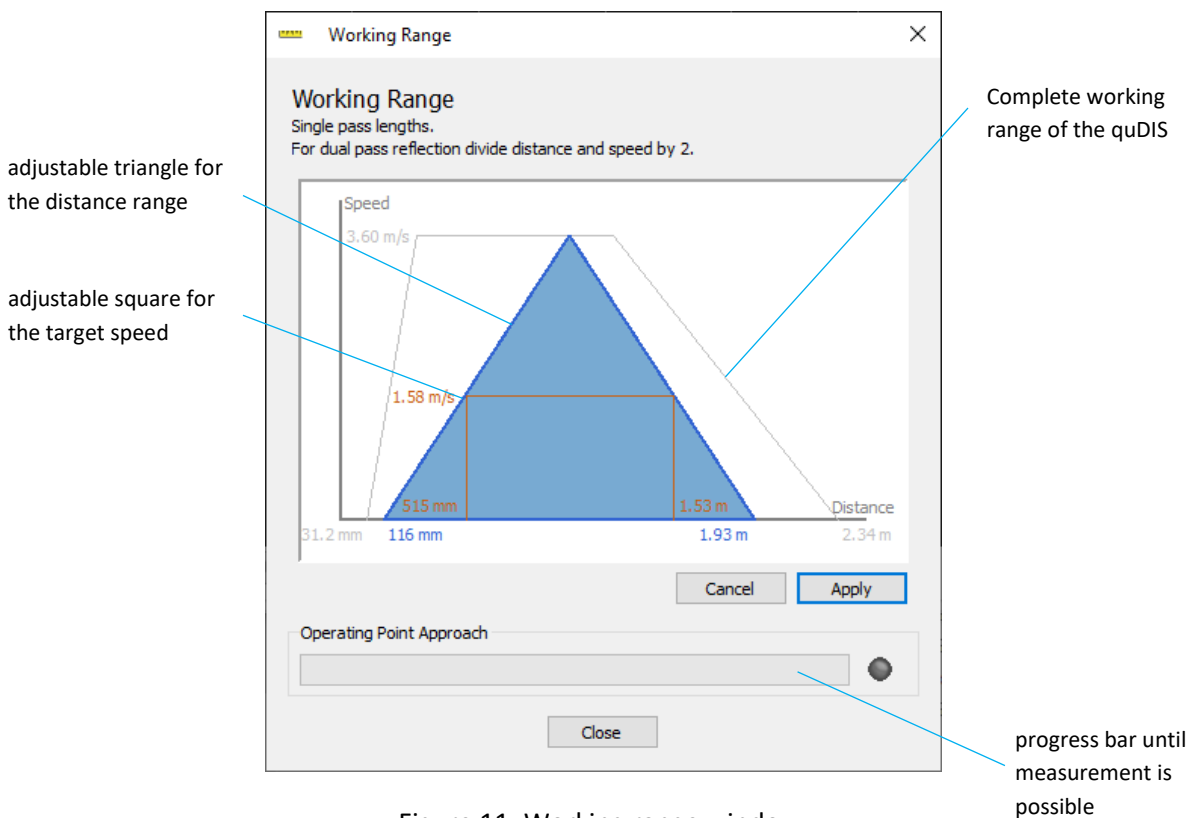

Figure 11: Working range window

## 9.4 Interfaces tab

Here, ethernet, quadrature and HSSL can be selected for the respective axes with the required parameters. The angle measurement can also be enabled here, and the required parameters can be entered (see angle [9.4.3 Angle measurement](#)).

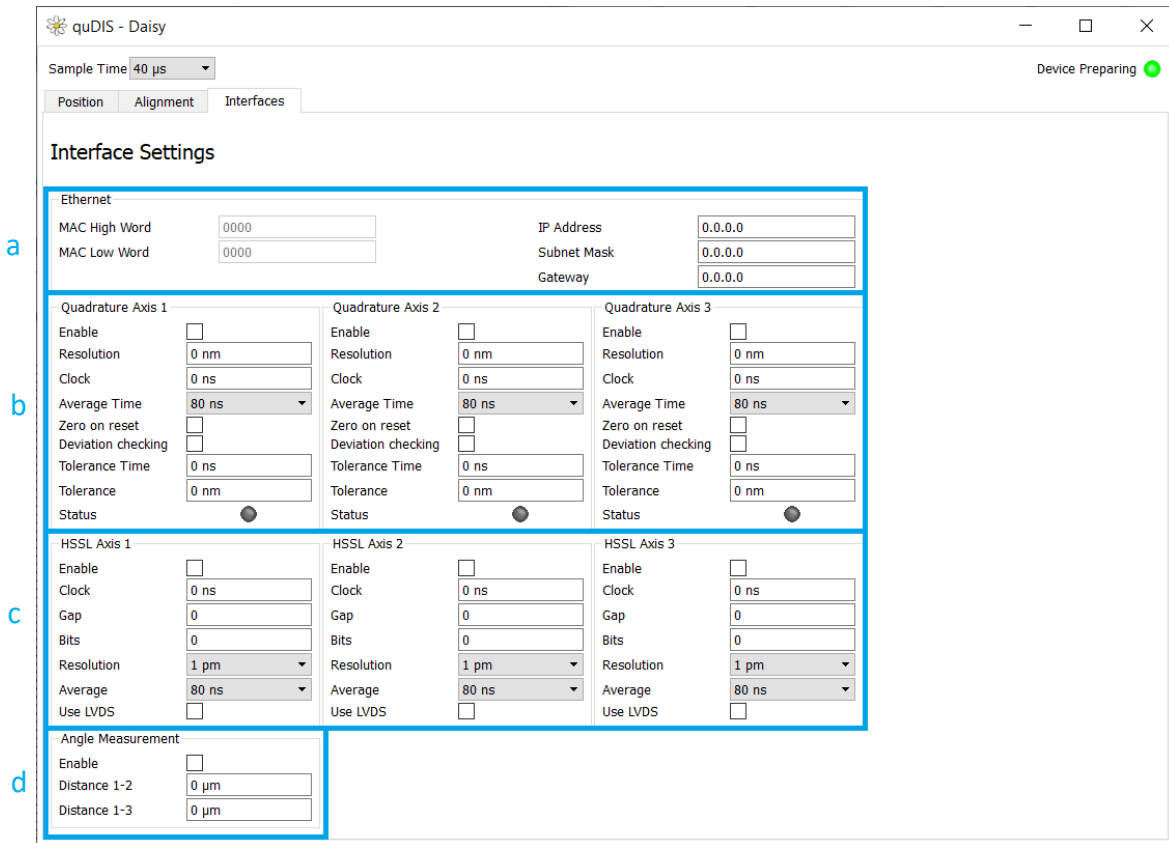

Figure 12: a: Ethernet  
 b: A-quad-B interface  
 c: HSSL interface  
 d: Angle measurement: Angular position instead axis 2,3

### 9.4.1 Ethernet

The PC connection to the quDIS can also be made via Ethernet. This feature is optional and can be bought with quDIS. It can also be activated later, see [8.3 Upgrade option](#).

To connect the quDIS via ethernet, it must first be connected via the USB3.0 port and the necessary network settings must be entered in the ethernet window.

### 9.4.2 A-quad-B and HSSL interfaces

There is an HDMI connection for each axis of the quDIS. A-quad-B and HSSL are available as interfaces for long and high-resolution measurements. The interfaces use different pins of the HDMI connector.

#### A-quad-B (quadrature) interface

A-quad-B is a digital interface that allows high resolution over a large range of data. It consists of two differential signals A and B. Every edge of a signal represents an adjustable step of displacement. The two signals have different phases with respect to the displacement, i.e., depending on the direction of motion, the edges of signal A or signal B appear earlier. This allows to determine the direction and to keep track of the displacement continuously. Before output, positions are averaged over an adjustable time.

The signals depend on three parameters:

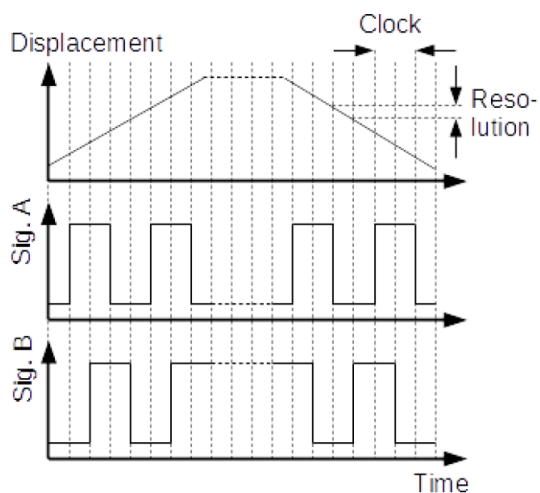

Figure 13: Diagrams of signals

Clock

The minimum time interval between two edges of a single signal. The minimum signal period is two times the clock value; the minimum time interval of steps (edges of different signals) is  $\text{clock}/2$ .

Resolution

The displacement represented by one step (a pair of edges in different signals).

Average time

Averaging time for the samples.

The combination of resolution and clock parameters defines a speed limit of  $\text{max. speed} = 2 \text{ Res} / \text{Clock}$ . If the target velocity exceeds that limit, the A-quad-B interface cannot follow, and the error signal is raised. (It is also raised if the displacement measurement is invalid.)

Example: Clock = 40 ns, Res = 65 nm: Limit = 3.25 m/s

Example: Clock = 1  $\mu\text{s}$ , Res = 25 pm: Limit = 25  $\mu\text{m}/\text{s}$

## A-quad-B settings in Daisy (Interfaces tab)

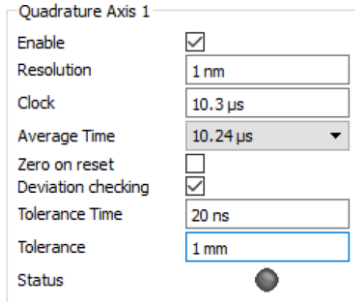

Quadrature Axis 1	
Enable	<input checked="" type="checkbox"/>
Resolution	1 nm
Clock	10.3 $\mu$ s
Average Time	10.24 $\mu$ s
Zero on reset	<input type="checkbox"/>
Deviation checking	<input checked="" type="checkbox"/>
Tolerance Time	20 ns
Tolerance	1 mm
Status	

Figure 14: Setting tab of A-quad-B

The A-quad-B signal can be enabled separately for every axis. The displacement represented by a pair of edges is adjusted by the “Resolution” parameter. It ranges from 1 pm to 1 mm, or from 1 n degree to 1 degree. “Clock” is the minimum time interval between two edges (40 ns ... 1.3 ms). The “Average Time” determines how many samples are averaged before output. “Zero on reset” means that the A-quad-B interface transmits virtual displacements that are caused by pressing the Reset button. If this box is not checked, a displacement reset has no effect at the interface. Measurement error and speed error can be signalled on the hardware error output and the “Status” indicator in the settings box. The error detection is switched on or off with “Deviation checking”. An error is detected if a deviation of “Tolerance” (1 pm ... 1 mm) or more lasts for the “Tolerance Time” (20 ns ... 1.3 ms) or longer.

### HSSL protocol

HSSL (High Speed Serial Link) is a synchronous serial protocol with two signal lines: CLK (clock) and DOUT (data out). The rising edge of CLK signals the presence of a new bit on DOUT.

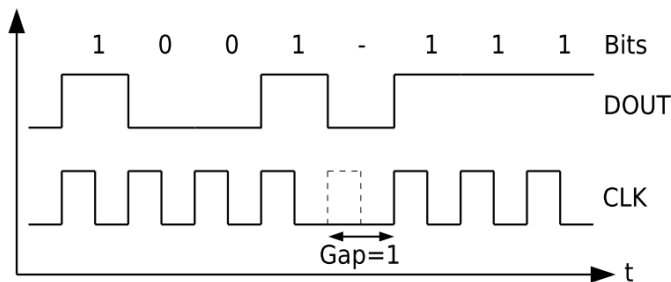

Figure 15: DOUT and CLK diagram

The quDIS sends the current displacement value of the respective axis repeatedly without any header or framing, coded in two's complement. Between two values, clock ticks may be left out to allow a reader to synchronize. The values have adjustable length and resolution of up to 48 bits / 1 pm. They are identical with the position displayed in the GUI and can be reset in the same way. Before output, positions are averaged over an adjustable time.

### HSSL settings in Daisy (interfaces tab)

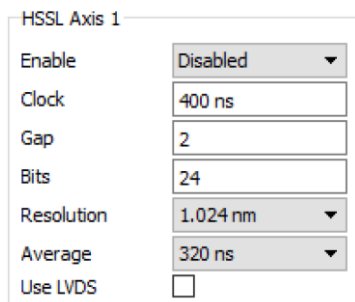

Figure 16: Setting tab of HSSL

The HSSL feature can be switched on per axis. The period of the clock signal is adjusted with the “Clock” parameter in the range from 40 ns to 2.5 μs. To allow synchronization, the clock signal can be paused between two displacement values. “Gap” determines the number of clocks left out and ranges from 0 to 63.

The “Bits” parameter regulates the number of bits a single HSSL value consists of (8 ... 48) while “Resolution” determines the physical distance represented by that value and ranges from 1 pm to 1.1 m. The average time for the samples can be chosen between 80ns and 2.6ms.

“Use LVDS” allows to use the differential LVDS output pins “POS-A” and “POS-B” instead of the regular LVTTTL pins “DATA-OUT” and “CLOCK-OUT” (see below).



### HDMI connectors

Every HDMI connector provides a quadrature signal and a serial position signal (HSSL) for its associated axis. The quadrature signal is differential; the serial signal is single ended.

The levels of the quadrature signal conform to the low-voltage differential signaling (LVDS) standard. LVDS is a current output and requires an appropriate termination in the range of 90 R to 130 R. A logical one is represented by  $U_{high}$  on the P-POS pin and  $U_{low}$  on the N-POS pin; a logical zero by  $U_{low}$  on the P-POS pin and  $U_{high}$  on the N- POS pin.

Load	Typ. LVDS $U_{low}$	Typ. LVDS $U_{high}$
100 R	+1.15 V	1.35 V

The Levels of the serial signal conform to LVTTTL;  $U_{low}$  represents a logical zero and  $U_{high}$  a logical one.

Load	Typ. LVTTTL $U_{low}$	Typ. LVTTTL $U_{high}$
No Load	+0.2 V	+3 V

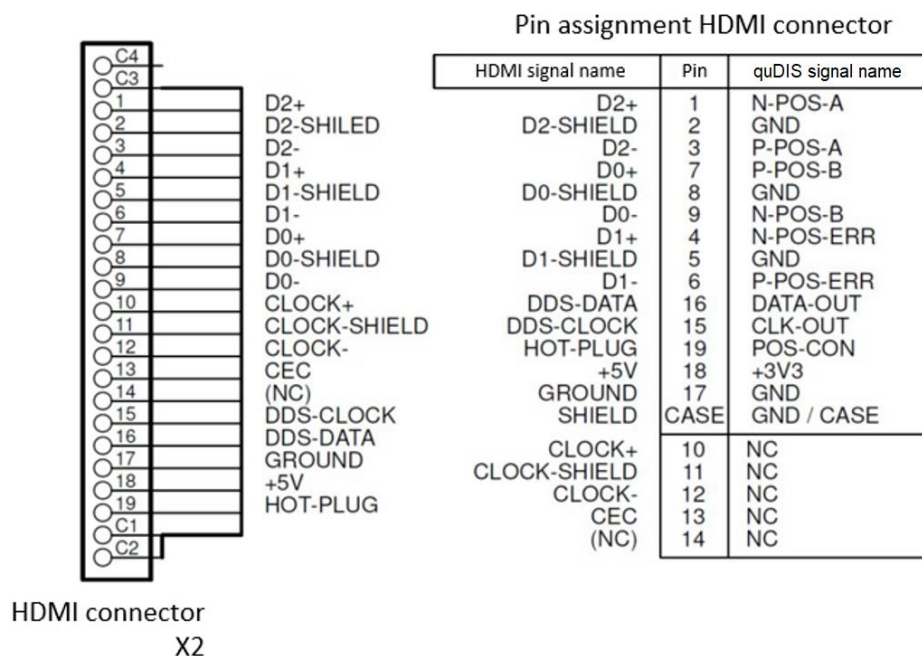

Figure 17 - Pin assignment of digital HDMI connectors with AquadB and HSSL

Name	Description	Levels
P-POS-A	Differential quadrature signal A	LVDS
N-POS-A	Complementary differential quadrature signal A	LVDS
P-POS-B	Differential quadrature signal B	LVDS
N-POS-B	Complementary differential quadrature signal B	LVDS
P-POS-ERR	Differential error signal, high active	LVDS
N-POS-ERR	Complementary differential error signal	LVDS
DATA-OUT	HSSL serial output: Data	LVTTTL
CLK-OUT	HSSL serial output: Clock	LVTTTL
+3V3	Power supply, max. 300mA	3.3V
GND	Ground	-
GND/CASE	Ground	-
POS-CON	Input, high active, signals a connected device	LVTTTL
NC	Not connected	-

Table 3: PIN description

### 9.4.3 Angle measurement

If an angle measurement is made, the sensor head must be adjusted (see 5.1.1 Align collimated single sensor axis). In the Daisy, the signal per axis is set to the maximum in the alignment tab. To be able to measure, the contrast must be greater than 2000.

After successful adjustment navigate to the interface tab, activate the angle measurement and enter the lateral distances between the collimators in mm.

There are collimator distances 1-2 and 1-3. The 1 represents the fixed collimator.

### 9.5 Single- and dual-pass

While aligning a sensor head, a phenomenon called dual pass can get visible. In this case, the measurement laser is reflected on the mirror back to the collimator and fiber end and then reflected to the mirror from the glass end of the fiber via the mirror and finally back into the fiber.

This gets visible when the double of the path length is displayed in the Daisy because the laser beam passes the measurement distance twice due to the alignment and the reflection on the glass end of the fiber.

### 9.6 Ambient Measurement Unit (AMU)



The quDIS Ambient Measurement Unit (AMU) is designed to compensate refractive-index changes induced by temperature ( $T$ ), pressure ( $p$ ) and relative-humidity ( $rH$ ) fluctuations with an overall accuracy of 1 ppm. For an accurate compensation measurement within the AMU specifications, it must be noticed that temperature, pressure, and relative humidity gradients are assumed to be constant along the working range, as the AMU sensors probe local variations of the environmental parameters.

A quDIS software update is required to operate the AMU. For further instructions about where to download and install the software, please consult 7. Software of the manual. Before you can use the AMU in combination with your quDIS device, you have to load the feature.ngc file in the Daisy software. Here you have to enter the unlock key provided. After doing so restart your device. In order to work correctly, the AMU has to be connected before starting the quDIS.

Once the AMU-compatible software version has been flashed in the quDIS, connect with the CAT 5e F/UTP patch cable the AMU (RJ45 side)

to the quDIS (Sensor output, 9pin D-SUB side).

Start the Daisy software and in the alignment-tab window adjust the working range settings according to your applications needs. In the panel AMU Sensor, you can see the LED which displays the connection status of the AMU.

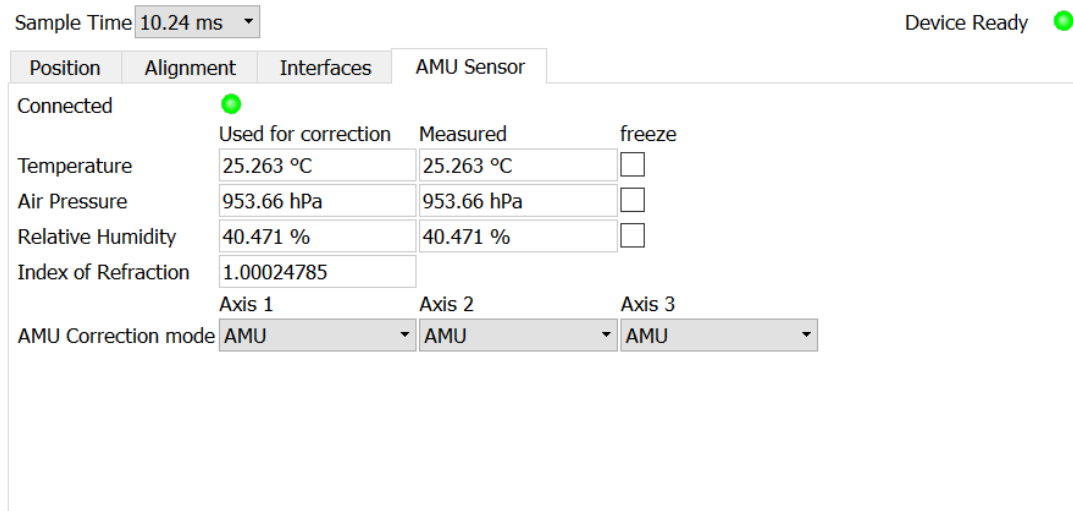

Underneath you find the temperature, pressure and relative humidity values which are used for the correction and are measured live by the AMU. You can freeze the three values individually by checking the box next to it. Doing so will keep the current parameter measured in the “used for calculation” box, while keeping the “measured” value up to date. Below this is displayed the value of the refractive index. By selecting the combo boxes you can choose to which axes you want to apply the AMU correction.

## 9.7 External Synchronization

With the external synchronization feature it is possible to have other devices synchronized with quDIS.

This feature is a buyable option for newer devices (see also [8.3 Upgrade option](#)).

Devices without the clock-connectors at the rear can't support this feature.

The device synchronization is done via a clock signal combined with a sweep synchronization / output start trigger signal. Both connect at the quDIS rear panel with SMA and 9-Pin D-Sub (see [6.1 Rear side](#)). We recommend using the same cable network for both clock and trigger so the signals run in parallel.

### Method of operation:

First both devices have to use the same clock. quDIS supports both clock in- and output to achieve this. Second the data acquisition interval and therefore the wavelength sweep has to be synchronized using the trigger.

For most applications it is also necessary to have a shared start event. Therefore, the quDIS can be set in a waiting mode for the start trigger, thus, no position output is happening and all FIFO's can be emptied or stay empty. In waiting mode, the first rising edge of the synchronization trigger input is used as the trigger event. Alternatively, the sync/start trigger can be emulated from the software.

As the quDIS is somewhere in the wavelength sweep when the trigger occurs, it will need some sweeps to synchronize (see Figure 18). The first position data is acquired as near as possible to the trigger event. With the following sweeps the quDIS will change the Sweep period to achieve matching trigger and data acquisition. The synchronization step will be finished within 100ms after the sync trigger.

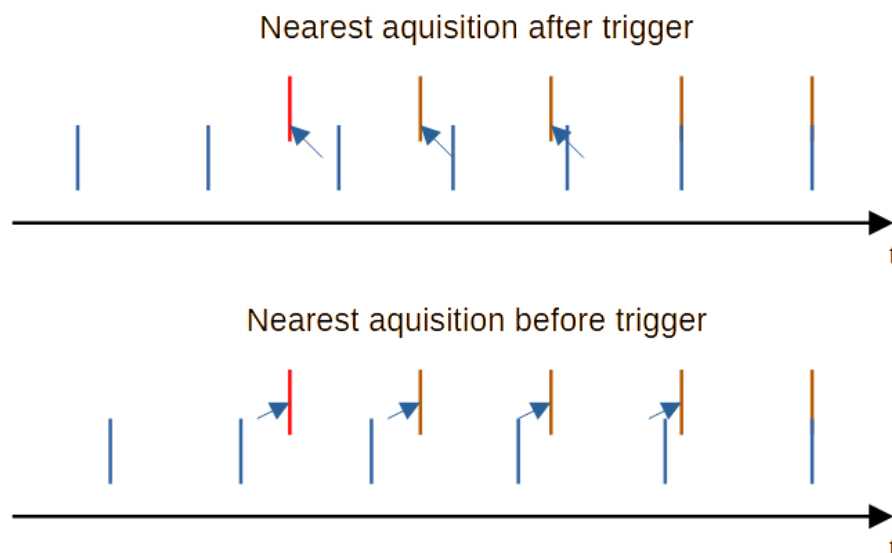

Figure 18 - Sweep Synchronization, red: trigger event, brown: quDIS internal periodical continuation of trigger event with fixed 25 kHz, blue: quDIS data acquisition, data acquisition period is altered to fit synchronization trigger timing.

### Steps to use Clock input

1. Physically connect the clock input when devices are switched off.
2. Start the devices.
3. Start Daisy, connect and go to the sync Tab (Figure 19).
4. Frequencies from 1 to 100 MHz will be detected automatically.  
For all other frequencies deactivate “auto assume” and click “configure clock”. Input your desired input frequency (Figure 20). The Difference should be “0 Hz”, so quDIS can work on this input frequency without deviation. Then close the window.
5. Make sure both checks under “measured frequency” are positive and the signal LEDs turn green.
6. Activate the external clock usage. The signal LED in front of “Clock in” should light up and stay green. The quDIS will wait for the next start/synchronization trigger if the clock was switched to external.

### Steps to use clock output

1. Physically connect the clock output at device rear when devices are switched off.
2. Start the devices.
3. Start Daisy, connect and go to the sync Tab (Figure 19).
4. Select a clock frequency and press “activate” in the row of “clock out”.
5. Check that the green LED in front lights up.

### Steps to synchronize sweep and start position output simultaneously

1. Physically connect the required input/output hardware at 9-pin D-Sub in the rear when devices are switched off.
2. Start the devices.
3. Start Daisy, connect and go to sync Tab (Figure 19).
4. Synchronize the clocks of all the devices.
5. Optionally set “sweep offset to trigger input”, if you want to compensate for signal travel time between devices. This field may be left empty.
6. Optionally set the resync behavior: Normally a periodical sweep sync pulse is used. If the deviation is above an epsilon, there will be a resync of the sweep.
7. If you want to start the position output simultaneously, make your master stop sending sweep synchronization pulses. Set all devices in waiting mode so no new position data will be sampled. The LED “Wait for Start/Sync Trigger” should light up while waiting. All data buffers

can be emptied now. The first sweep synchronization pulse will be used to start all position output.

8. Execute the trigger event from top to bottom of your trigger network. One device should act as master and all other devices react to it as slaves. This can be done in different ways:
  - a. There is an external sync event at quDIS hardware input.
  - b. Press the button “emulate one” to emulate a synchronization signal/event. This has the same effects as a), but the quDIS gets the command from the software.
  - c. Press the button “out once”. The next possible data acquisition point in quDIS sweep is used as start and output trigger. The quDIS is used as master, but the wavelength sweep of the used quDIS master stays untouched.
  - d. Any quDIS receiving a sync input event will generate a sync output event, which can be used for synchronization of further devices. There will be a short delay though. If you don't want this behavior, disable loop.
9. If it is necessary to repeat the Sweep Synchronization or position output start, it is not needed to synchronize the clocks again. You may just repeat step 7 and 8.

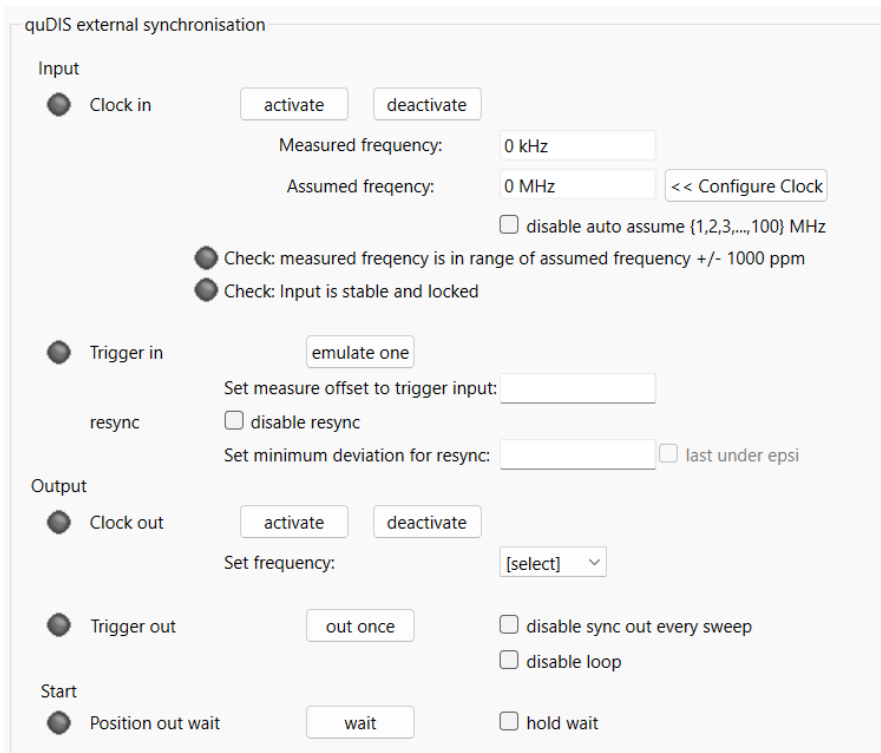

Figure 19 - External Synchronization GUI, Tab is displayed when feature is activated, the source can be found in the modules folder.

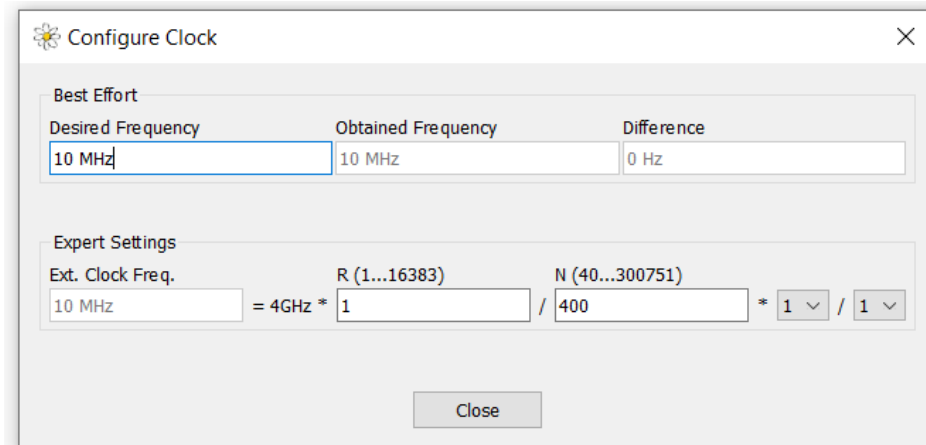

Figure 20 - Sub window for Clock input configuration

### Trigger chain through devices

If a sync trigger event arrives at input, it will be also forwarded to the sync output. This way it is possible to chain the trigger signal through multiple devices. Be aware that there will be a signal delay from input to output, which can be compensated with a trigger input offset in all consecutive devices.

The accumulating offset for each quDIS device in the chain is about 200 ns. The exact value depends on the used firmware version.

Rest of deviation in sweep synchronization:

The analog trigger event is a point of time, while the data acquisition for relative position measurement is a time interval from which the center is used in terms of synchronization.

Even when properly synchronized, there remains a small residual deviation from data acquisition time center compared to the trigger event.

Device internal effects lead to a device and firmware dependent deviation of up to 30 ns with an uncertainty of +/- 10 ns in total.

Device external effects are electrical signal pulse travel time and light travel time. The used fiber length from measurement cavity to quDIS input is adding a time offset with approximately 5 ns per meter.

## 10. Measurements

This paragraph describes the distance and angle measurement with Daisy in detail. Initially, the sensor head must be aligned as described in 5.1.1 Align collimated single sensor axis and connected to the quDIS.

The quDIS connected to a PC via USB can then be started. To do this, set the power switch to "1" on the back and then press the ON / OFF button on the front until it lights up blue. The quDIS needs some seconds for start-up. The USB-connection can be established after some seconds. When starting the Daisy.exe it will try to initialize the USB connection to the quDIS.

Now the Daisy.exe can be started (initially the quDIS may have to be flashed, see 7. Software).

This usually takes about 1 minute and is indicated by the state of the light in the upper-right corner. If "Device Ready" is displayed, the measurement can be started. In the Position tab. When the start procedure is completed, the curves in the diagrams are stabilized.

The contrast of the axes can now be viewed in the alignment tab and the working range can be set. To do this, the Working Range window is opened with the corresponding button. Both the working range and the speed of the target can now be set there by adjusting the triangle and square limits. By pressing "Apply" the parameters are saved and the quDIS adapts to them - shown in the "Operating Point Approach" diagram.

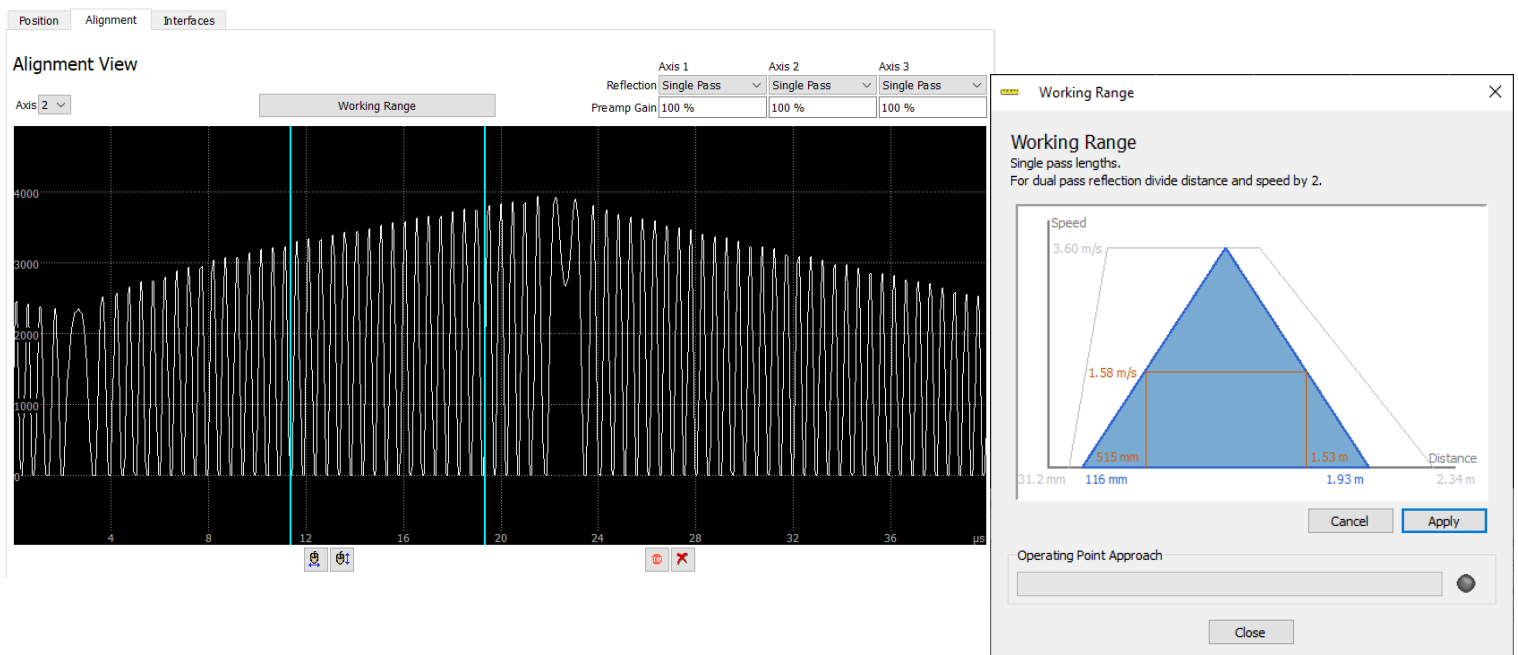

## 10.1 Relative measurement

As described in 9.2, the measurement can now be carried out with its corresponding diagrams and values.

## 10.2 Angle measurement

As described in 9.4.3, the angle measurement is activated in the Interfaces tab and the distance between the collimators is entered in mm. The position tab now shows the relative angle changes in relation to the two other collimators.

With “Rest All” the "zero position" to the target can be set.



Figure 21: Position tab with angle measurement

## 11. Quick-start-guide

- 1) To begin a measurement, connect the quDIS to a computer via USB and ensure it is switched on.
- 2) Start Daisy.exe.
- 3) Go to the Alignment Tab.
  - a) The working range can now be set by opening the Working Range window. Here, by moving the triangle, the working range and the maximum speed of the target can be set and applied with "Apply". After the device configuration process "Device Ready" will light up green.
  - b) When looking at the Alignment View axis, it must be amplitude higher than 2000, the higher the better. If its not consider a proper axis alignment.
- 4) Device Ready can be seen in the top right corner of the Position tab. Wait until the green light comes on and the position curves have stabilized.
- 5) After the alignment is finished, the quDIS should now display correct position values on all three displays in the position tab.

For FAQ see chapter [12](#).

## 12. FAQ / Troubleshooting

<b>Problem</b>	The relative displacement is approximately twice the actual displacement.
<b>Cause</b>	The Cavity is aligned in dual pass. Due to the nature of the Fabry-Perot cavity formed between the target and the end of the optical fiber, frequencies corresponding to multiple cavity roundtrips can also be present in the signal, and the measurement algorithm has fallen into the dual-pass frequency.
<b>Solution</b>	To correct a dual pass problem, either change to dual pass in alignment tab (9.5) or align to single pass (5.1.1)“
<b>Problem</b>	The quDIS does not achieve the status “Device Ready”
<b>Cause</b>	The quDIS start-up is still running or failed.
<b>Solution</b>	Wait 2 more minutes. If “device ready“ is not achieved, try restarting both quDIS and Software. If still not working contact your distributor.
<b>Problem</b>	The Daisy software warns that the firmware version does not match the software version.
<b>Cause</b>	In many cases new software packages come along with new firmware files. The software can work correctly only if the matching firmware is installed.
<b>Solution</b>	Run the flasher tool “nhflash(.exe)” of the new software package and press “Flash” to update the firmware.
<b>Problem</b>	Despite attempted optical alignment, no position data are displayed in the position tab and only small or no fringes are visible in the interferogram in alignment tab
<b>Cause</b>	Poor alignment
<b>Solution</b>	Attempt to realign the optics so that more light is captured by the sensor head(s).

## 13. Known Bugs

Version 2.2.8

- 1) When updating from Version 2.1.3 to Version 2.2.8 the short range mode must be deactivated manually or the position measurement will fail.
- 2) External clock feature can't be activated via option upgrade key.